

# LED Site / Roadway / Post Top Series

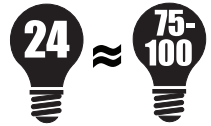

Stock No.      Product Description

**LED-8019      PT-120/277-24-50-DL (Daylight)**

**Description:**

Fully encapsulated, 120 - 277 Volt, E27 mounting that integrates energy saving LED technology into a powerful yet energy saving SMD LED stubby outdoor post top lamp. Available in Daylight (DL).

- 24 Watt
- 120 - 277 Volt operation
- Daylight DL (5500K)
- 1150 lumens
- 50 on-board LED SMDs
- Up to 35,000 hour lamp life
- Minimal heat output
- 360° illumination plus top light
- Not dimmable
- 3 year warranty

**Applications:**

LED Site / Roadway / Post Top Series lamps can impact energy usage and costs in a major way for communities and housing developments with minimal to no maintenance costs thanks to the up to 35,000 hour lamp life.

- Site / Roadway / Post Top
- Wall packs (where applicable)
- Security lighting
- Parks and quads
- Municipal lighting

**Packaging:**

Master-pack:      20 each

**NOTE: When retrofitting LED to HID fixture, ballast must be by-passed when present. Eliminating the ballast saves additional costs related to maintenance, energy consumption and performance. Additionally, by-passing ballast will insure no RFI interference.**

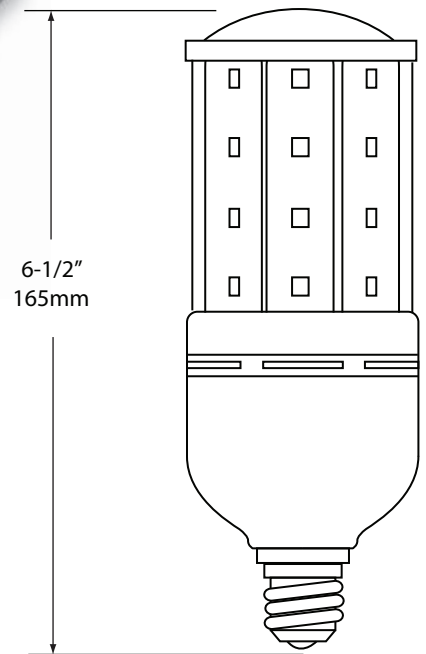

OVERHEAD VIEW

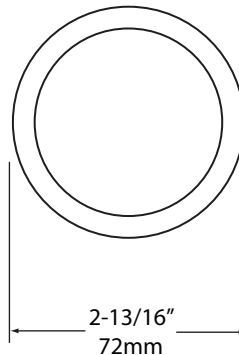

**Technical Specifications:**

|                 |                                   |                |                   |
|-----------------|-----------------------------------|----------------|-------------------|
| Bulb Type:      | Cylindrical                       | Mounting:      | E27               |
| Bulb            | PC tube                           | Replaces:      | 75/100W HPS       |
| Material:       | PBT plastic base.                 | Life Time:     | Up to 35,000 Hrs. |
| Output Power:   | 24W                               | Input Voltage: | AC 120 - 277V     |
| Lumens:         | 1150                              | Beam Angle:    | 360°              |
| Dimensions:     | 2-13/16" x 6-1/2"<br>72mm x 165mm | Kelvin Temp.:  | (DL) 5500K        |
| Lumen per Watt: | 48                                | LEDs:          | 50                |

Note: All specification information falls within a ± 2% range

NOTE: Light Emitting Designs is providing this information to the general public. Please note that all products contained herein are trademarked, copyrighted, and/or have patents pending. Any use of these designs is strictly prohibited without prior written consent. Light Emitting Designs protects its proprietary information vigorously in the courts of the United States of America.



[Green Electrical Supply](http://GreenElectricalSupply.com)

[GreenElectricalSupply.com](http://GreenElectricalSupply.com)

Our Customer Service Department is here to assist you at 877-652-9640